

IT IS DIFFERENT SWASH PLATE

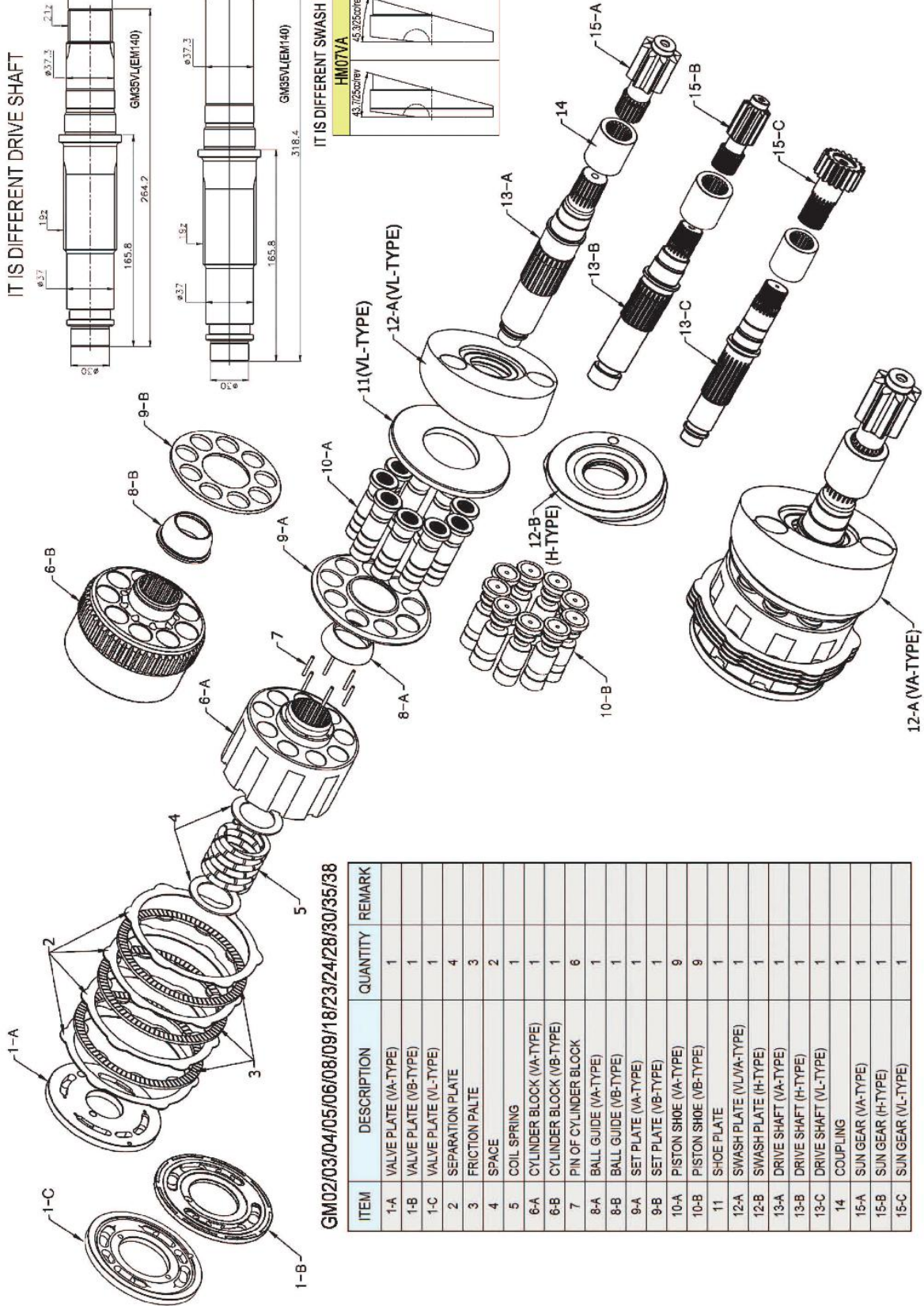

GM02/03/04/05/06/08/09/18/23/24/28/30/35/38

ITEM	DESCRIPTION	QUANTITY	REMARK
1-A	VALVE PLATE (VA-TYPE)	1	
1-B	VALVE PLATE (VB-TYPE)	1	
1-C	VALVE PLATE (VL-TYPE)	1	
2	SEPARATION PLATE	4	
3	FRICTION PALTE	3	
4	SPACE	2	
5	COIL SPRING	1	
6-A	CYLINDER BLOCK (VA-TYPE)	1	
6-B	CYLINDER BLOCK (VB-TYPE)	1	
7	PIN OF CYLINDER BLOCK	6	
8-A	BALL GUIDE (VA-TYPE)	1	
8-B	BALL GUIDE (VB-TYPE)	1	
9-A	SET PLATE (VA-TYPE)	1	
9-B	SET PLATE (VB-TYPE)	1	
10-A	PISTON SHOE (VA-TYPE)	9	
10-B	PISTON SHOE (VB-TYPE)	9	
11	SHOE PLATE	1	
12-A	SWASH PLATE (VL/VA-TYPE)	1	
12-B	SWASH PLATE (H-TYPE)	1	
13-A	DRIVE SHAFT (VA-TYPE)	1	
13-B	DRIVE SHAFT (H-TYPE)	1	
13-C	DRIVE SHAFT (VL-TYPE)	1	
14	COUPLING	1	
15-A	SUN GEAR (VA-TYPE)	1	
15-B	SUN GEAR (H-TYPE)	1	
15-C	SUN GEAR (VL-TYPE)	1	

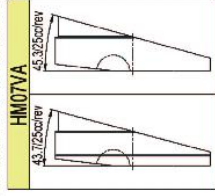

# GM SERIES



IT IS DIFFERENT SWASH PLATE

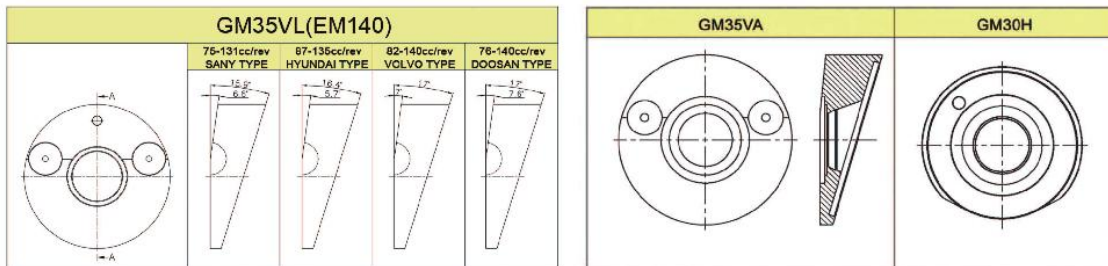

IT IS DIFFERENT DRIVE SHAFT & SUN GEAR

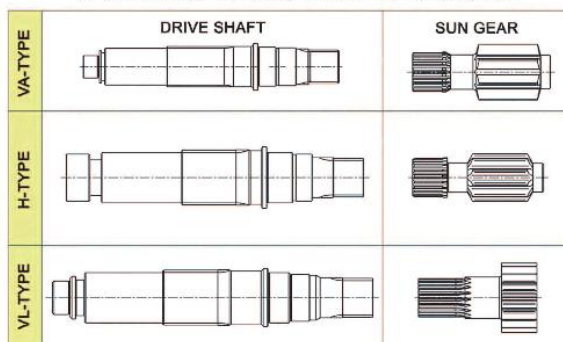

IT IS DIFFERENT VALVE PLATE

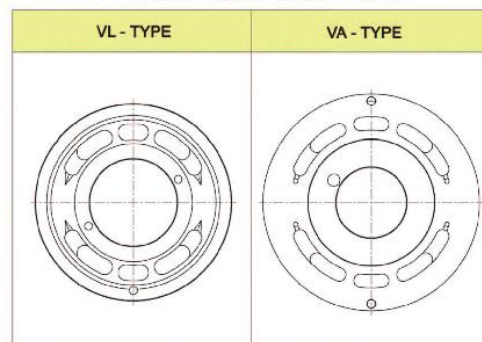

IT IS DIFFERENT COUPLING

