

# H3VL28

## LOAD SENSING & CUT-OFF CONTROL

### SWASH PLATE TYPE PISTON PUMP



#### SPECIFICATIONS

<b>MODEL</b>	H3VL28
<b>Discharge Rate(cc/rev)</b>	28
<b>Max. Pressure (kg/cm<sup>2</sup>)</b>	340
<b>Max. Speed (rpm)</b>	3000

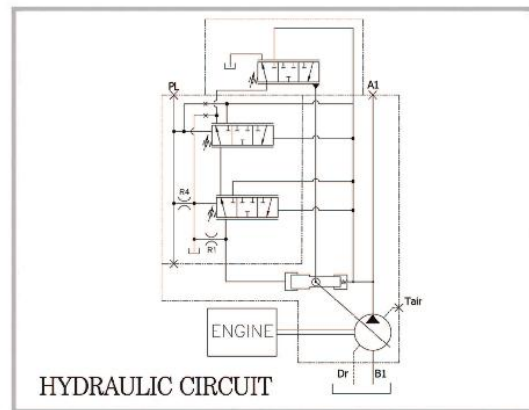

#### Dimensions of Shaft End(Spline Type)

MODEL	No. of teeth	Pitch Circle Dia(mm)	Mouldle	Pressure Angle	Standard
H3VL28	13	20.64	16/32	30	SAE J498B

#### Dimensions of Shaft End(Key Type)

MODEL	a	b	c	d	e	f	Standard
H3VL28	22.2	24.9	28	6.3	9	41	SAE J744-22-1

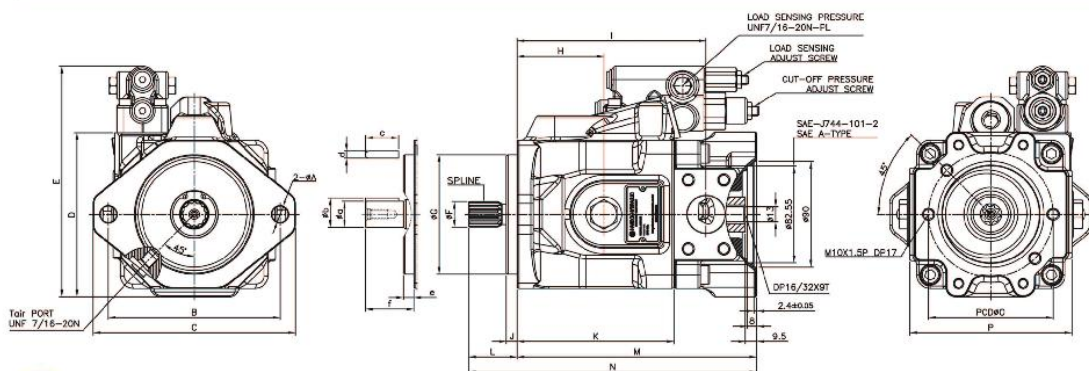

#### DIMENSIONS

(mm)

MODEL	A	B	C	D	E	F	G	H	I	J	K	L	M	N	O	P
H3VL28	14	146	172	139.5	196	21.7	101.6	74	161	9	134	41	204	245	106	138