

# H7V63DTP SWASH PLATE TYPE DOUBLE PISTON PUMP



## SPECIFICATIONS (FOR 9X2D / 9Y2C TYPE)

MODEL	H7V63DTP
Discharge rate(cc/rev)	63
Max. pressure (kg/cm <sup>2</sup> )	350
Max. speed(rpm)	2400



## Dimensions of Shaft End(Spline Type)

MODEL	No. of teeth	Pitch circle dia(mm)	Module	Pressure angle	Standard
H7V63DTP	14	29.96	12/24	30°	SAE

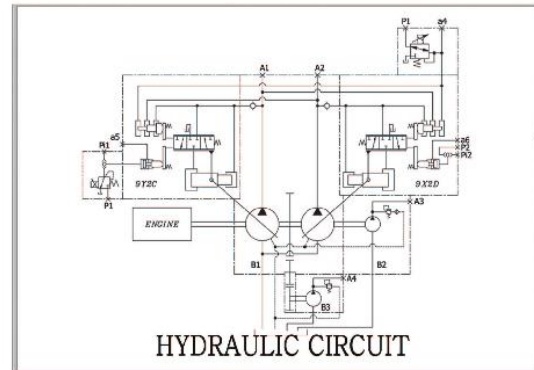

## Dimensions of Shaft End(Spline-A)

MODEL	No. of teeth	Pitch circle dia(mm)	Module	Pressure angle	Standard
H7V63DTP	10	15.88	16/32	30°	ANSI B92.1 1970

## Dimensions of Shaft End(Spline-B)

MODEL	No. of teeth	Pitch circle dia(mm)	Module	Pressure angle	Standard
H7V63DTP	13	13	1.0	30°	JIS B 1603 :1995

## Flange Mounting face for Suction Port

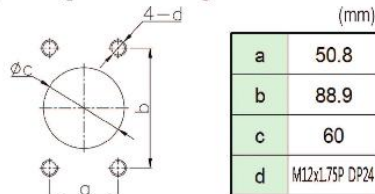

## Flange Mounting face for Delivery Port

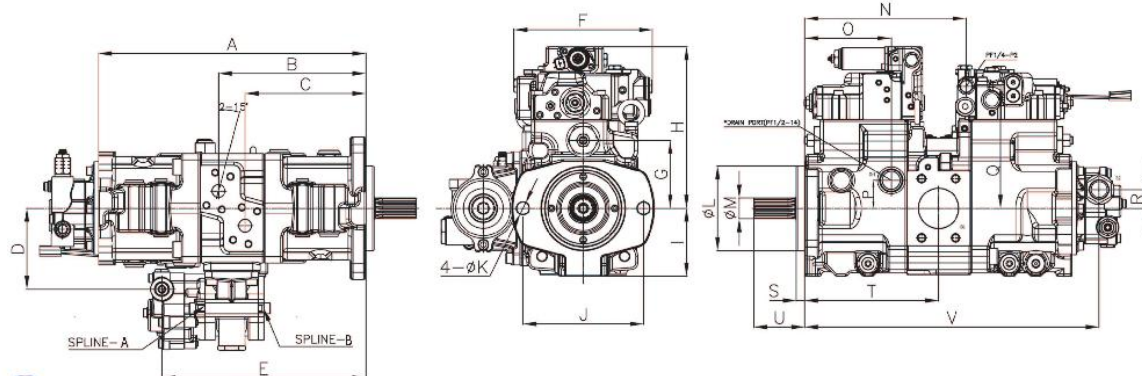
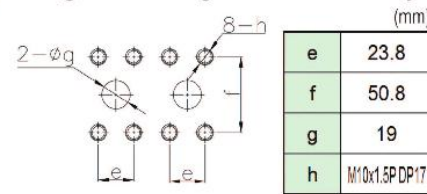

## DIMENSIONS

(mm)

MODEL	A	B	C	D	E	F	G	H	I	J	K	L	M	N	O	P	Q	R	S	T	U	V
H7V63DTP	401	221	181	121	306	208	102	242	102	181	18	127	31.2	242.5	130	18	127	31.2	12.5	201	76.2	442

# H7V63DTP SWASH PLATE TYPE DOUBLE PISTON PUMP



## SPECIFICATIONS(FOR 9N00 TYPE)

MODEL	H7V63DTP
Discharge rate(cc/rev)	63
Max. pressure (kg/cm <sup>2</sup> )	350
Max.speed(rpm)	2400

## Dimensions of Shaft End(Spline Type)

MODEL	No. of teeth	Pitch circle dia(mm)	Module	Pressure angle	Standard
H7V63DTP	14	29.96	12/24	30°	SAE

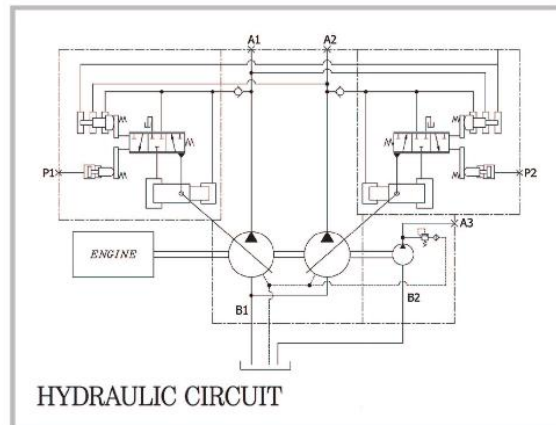
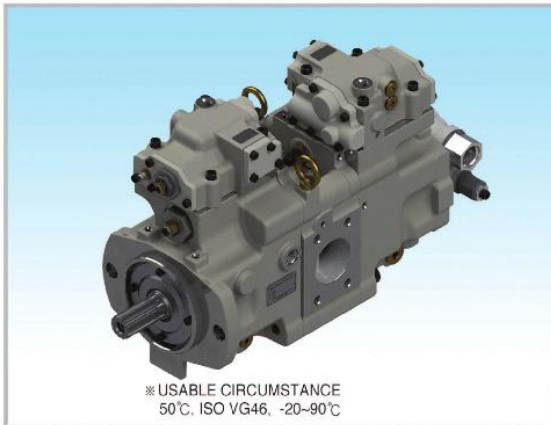

## Flange Mounting face for Suction Port

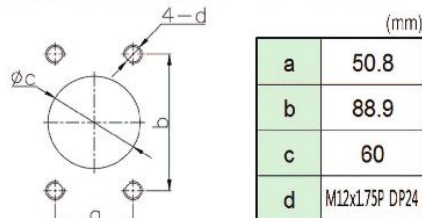

## Flange Mounting face for Delivery Port

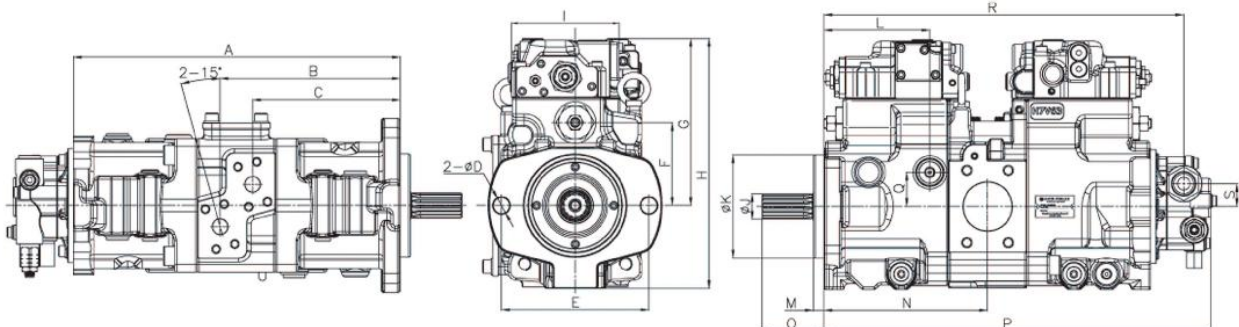
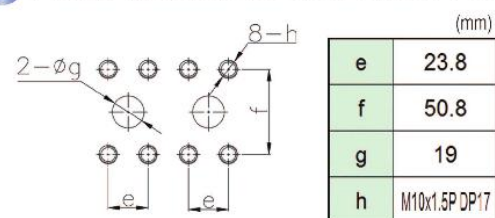

## DIMENSIONS

MODEL	A	B	C	D	E	F	G	H	I	J	K	L	M	N	O	P	Q	R	S
H7V63DTP	401	221	181	20	181	102	205	307	131.5	31.2	127	130	12.5	201	76.2	475	42	442	28

# H7V63DTP SWASH PLATE TYPE DOUBLE PISTON PUMP



## SPECIFICATIONS (FOR 9C00 TYPE)

MODEL	H7V63DTP
Discharge rate(cc/rev)	63
Max. pressure (kg/cm <sup>2</sup> )	350
Max. speed(rpm)	2400

## Dimensions of Shaft End(Spline Type)

MODEL	No. of teeth	Pitch circle dia(mm)	Module	Pressure angle	Standard
H7V63DTP	14	29.96	12/24	30°	SAE

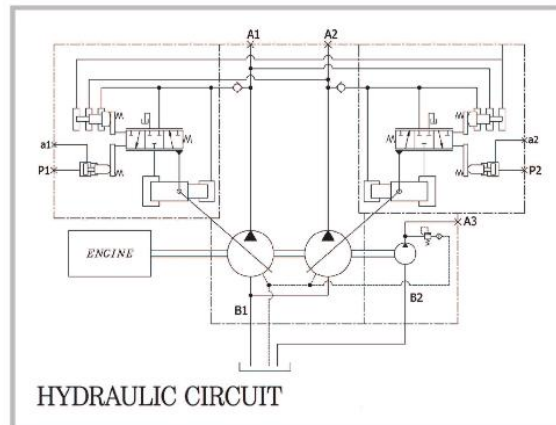
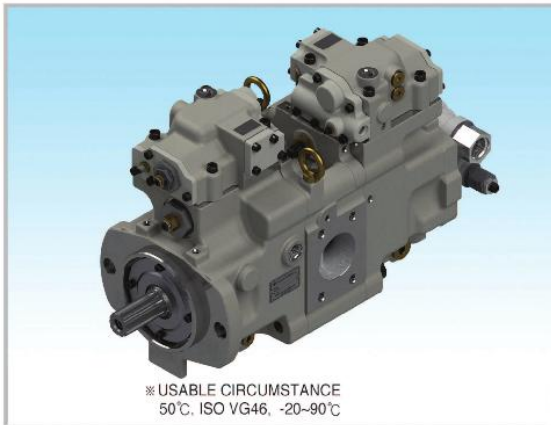

## Flange Mounting face for Suction Port

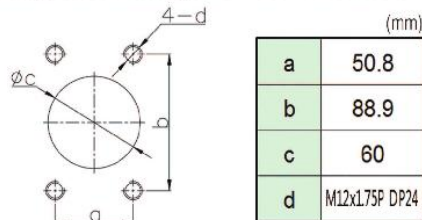

## Flange Mounting face for Delivery Port

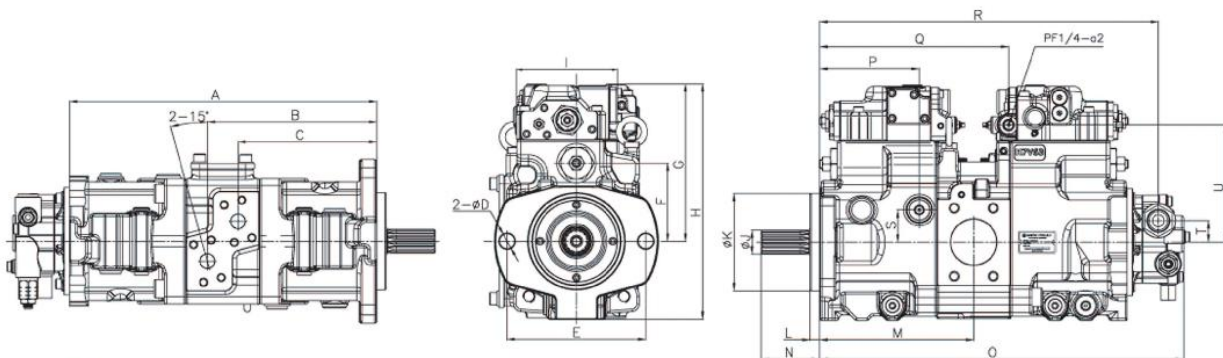
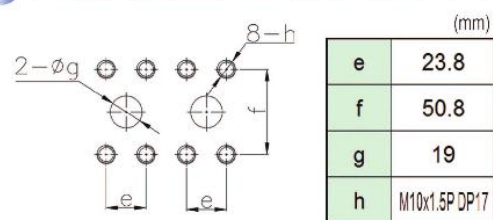

## DIMENSIONS

(mm)

MODEL	A	B	C	D	E	F	G	H	I	J	K	L	M	N	O	P	Q	R	S	T	U
H7V63DTP	401	221	181	20	181	102	205	307	131.5	31.2	127	12.5	201	76.2	475	130	246.5	442	42	28	153