

REGULATOR FOR CATERPILLAR (3L2E)

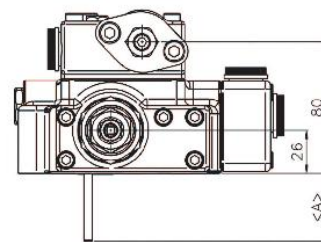
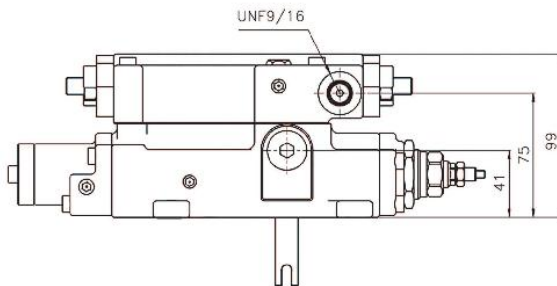
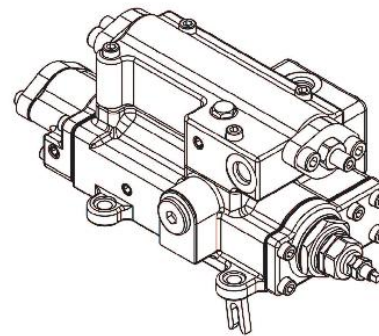
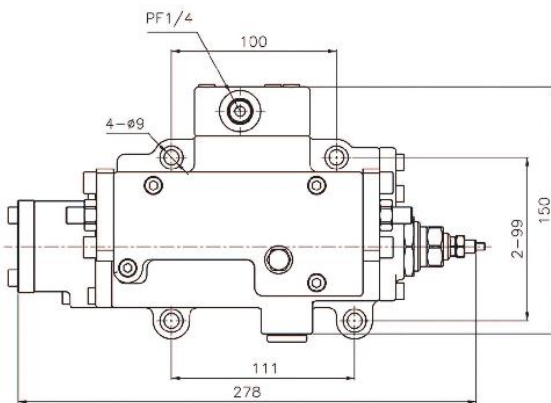
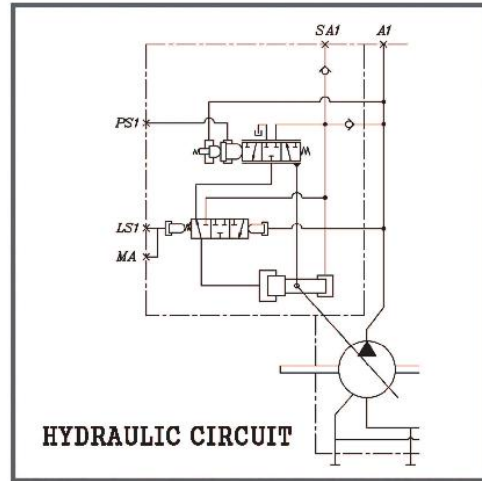

● STANDARD DIMENSIONS

(mm)

MODEL	A	MODEL	A
H3V63	25.5	H5V80	44
H3V112	39.5	H5V140	51
H3V140&180	60.5	H3V280	79.2
H5V160 & 200	69.5	H5V160DPH & 200DPH	

REGULATOR FOR CATERPILLAR(HBS80)

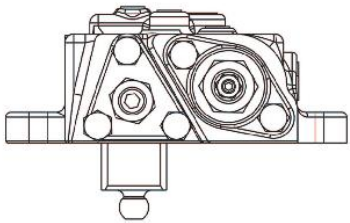
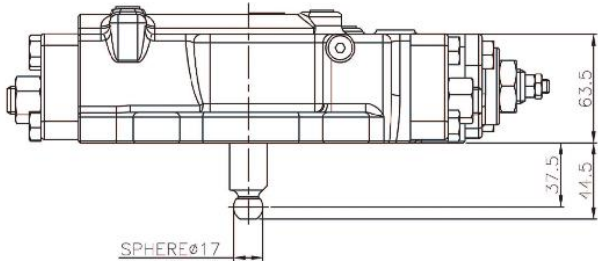
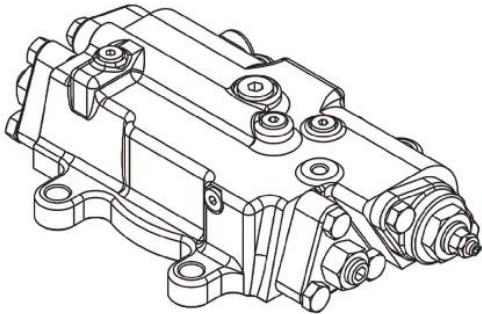
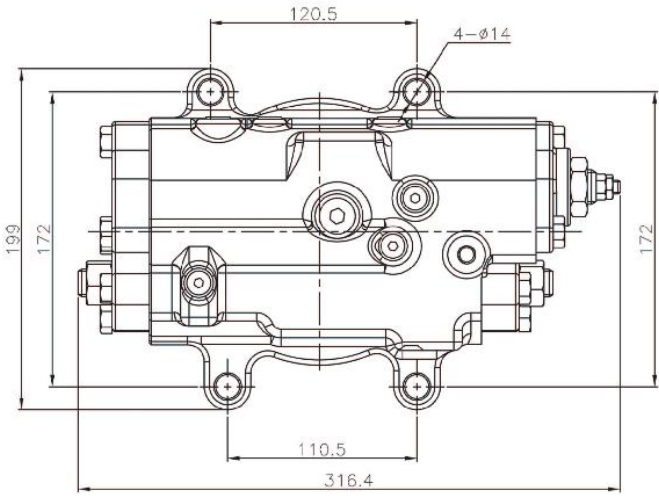
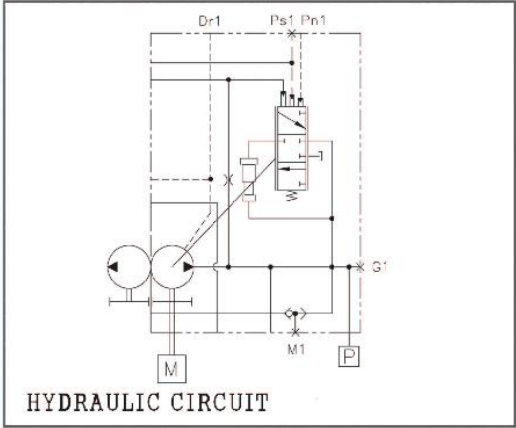

REGULATOR FOR CATERPILLAR(HBS120&140) FRONT TYPE

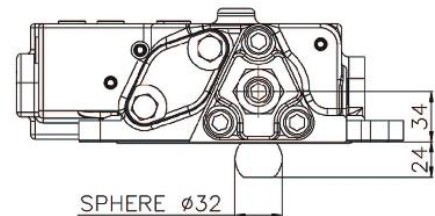
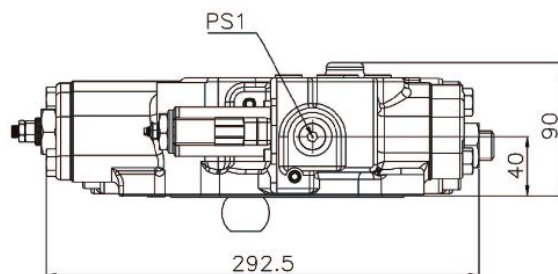
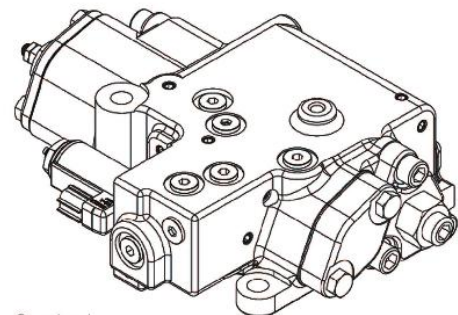
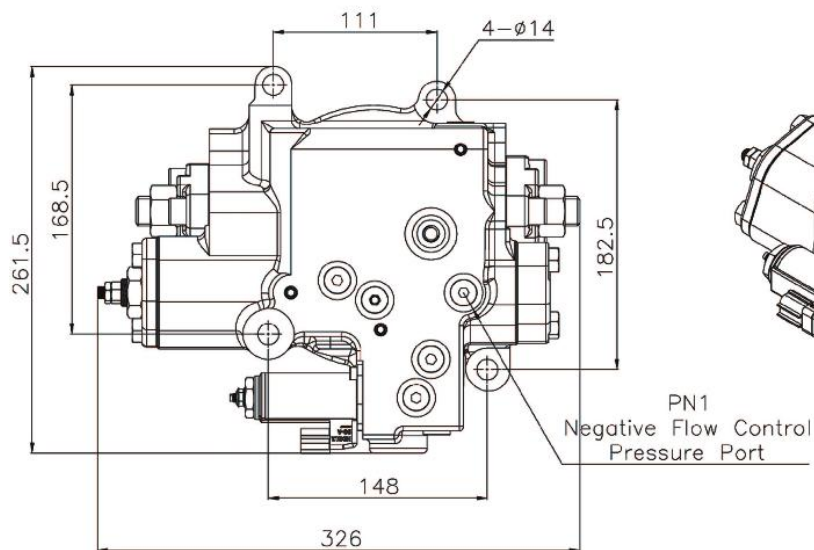
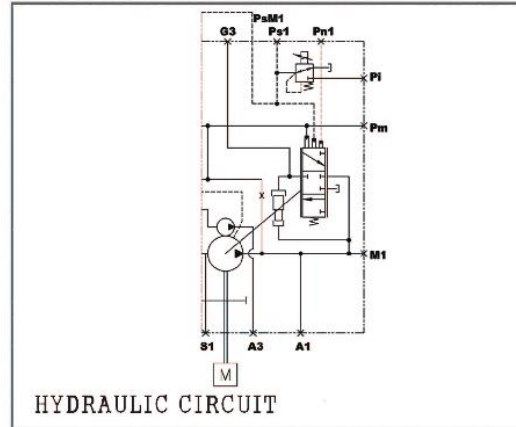

REGULATOR FOR CATERPILLAR(HBS120&140) REAR TYPE

