

H3VL63/80 SWASH PLATE TYPE PISTON PUMPS

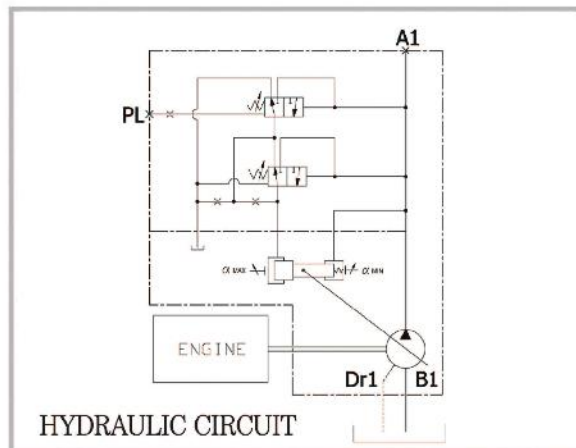

SPECIFICATIONS (FOR LC00 TYPE)

MODEL	H3VL63	H3VL80
Discharge Rate(cc/rev)	63	80
Max. Pressure (kg/cm ²)	280	350
Max. Speed (rpm)	2400	

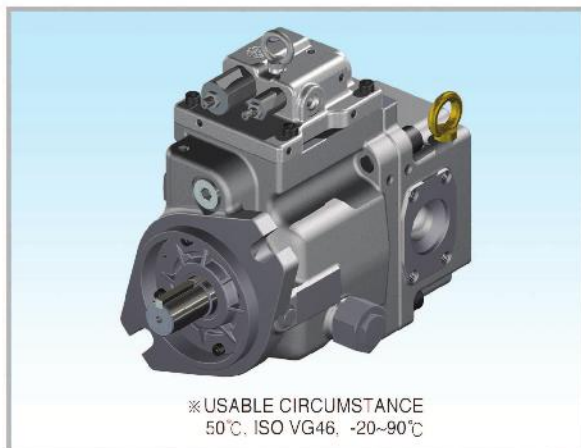

Dimensions of Shaft End(Key Type)

MODEL	a	b	c	d	e	f	Standard
H3VL63/80 (SAE KEY)	31.75	35.2	44	7.94	12.7	56	SAE J744-32-1
H3VL63/80 (ISO KEY)	32	35	50	10	9	68	ISO 3019/2-G32N

Dimensions of Shaft End(Spline Type)

MODEL	No. of teeth	Pitch Circle Dia.(mm)	Module	Pressure Angle	Standard
H3VL63/80	14	29.63	12/24	30°	SAE J744-32-4
H3VL63/80	12	30	2.5	20°	JIS B 1603 : 1995

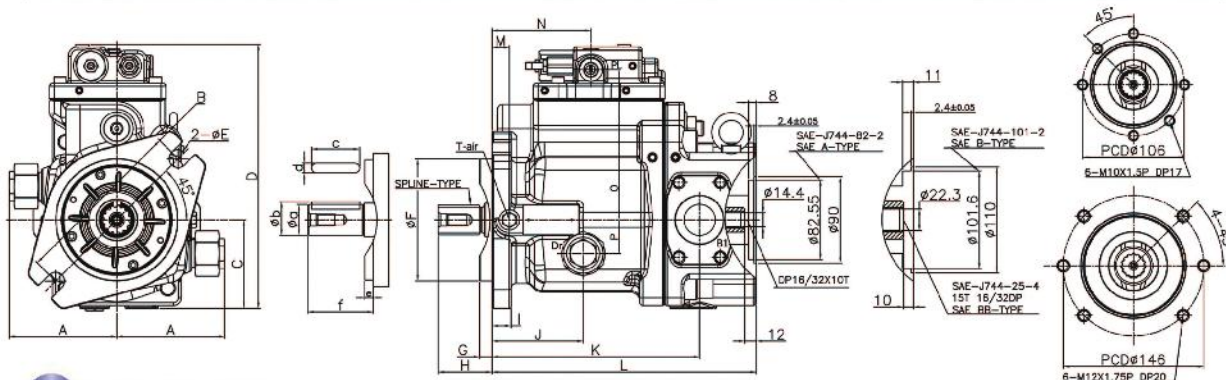

DIMENSIONS

(mm)

MODEL	A	B	C	D	E	F	G	H	I	J	K	L	M	N	O	P
H3VL63/80	112	180	92	275	18.5	127	12.7	56	20	95	216	275	18	103	156	35

H3VL28

LOAD SENSING & CUT-OFF CONTROL

SWASH PLATE TYPE PISTON PUMP



SPECIFICATIONS

MODEL	H3VL28
Discharge Rate(cc/rev)	28
Max. Pressure (kg/cm²)	340
Max. Speed (rpm)	3000

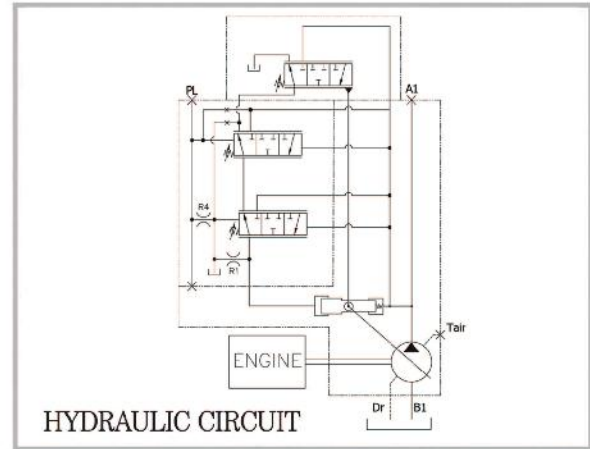

Dimensions of Shaft End(Spline Type)

MODEL	No. of teeth	Pitch Circle Dia(mm)	Moudle	Pressure Angle	Standard
H3VL28	13	20.64	16/32	30	SAE J498B

Dimensions of Shaft End(Key Type)

MODEL	a	b	c	d	e	f	Standard
H3VL28	22.2	24.9	28	6.3	9	41	SAE J744-22-1

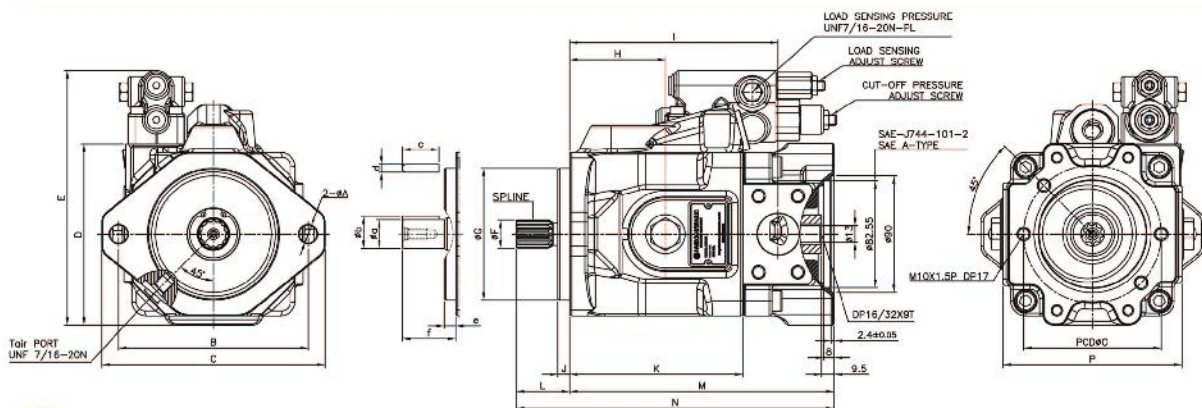

DIMENSIONS

(mm)

MODEL	A	B	C	D	E	F	G	H	I	J	K	L	M	N	O	P
H3VL28	14	146	172	139.5	196	21.7	101.6	74	161	9	134	41	204	245	106	138